



AGENDA

South Dallas Urban Renewal District Advisory Committee

Thursday, March 28, 2024 12:45 pm – 1:30 p.m.

Immediately Following the Economic Development Commission Meeting

Dallas City Hall

Members: Brian Dalton, Peter Cairns, Bob Tucker, Craig Pope, Erik Andersson, Jim Bauer, Rita Grady

Staff Contact: Tyler Ferrari

1. Approval of January 25, 2024 Minutes
2. Staff Reports
 - a. Budget & Tax Revenue Report
3. Urban Renewal Plan Walkthrough
4. Initial Property Owner Outreach
5. Commission Chair discussion
6. Member Comments
7. Other Business
8. Adjourn 1:30 p.m.

Upcoming 2024 SDURDAC Meetings

--

May 23rd

July 25th

September 26th

November 21st



South Dallas Urban Renewal District Advisory Committee

Engineering Conference Room

187 SE Court Street, Dallas, OR

January 25, 2024 immediately following Economic Development Commission Meeting

1 **ROLL CALL**

2 Members Present: Chair, Rita Grady; Vice Chair, Peter Cairns; Bob Tucker; Craig Pope; Brian Dalton; Erik
3 Andersson; and Jim Bauer

4 Staff present: Economic and Community Development Director, Charlie Mitchell; Economic Development
5 Specialist, Tyler Ferrari; and Recording Secretary, Benjamin Curry

6
7 The meeting commenced at 1:05 p.m.

8
9 **ELECTION OF OFFICERS**

10 Mr. Pope made a motion to elect the current slate of officers of the Economic Development Commission to
11 serve as Chair and Vice Chair of the South Dallas Urban Renewal District Advisory Committee. Ms. Grady
12 declined the nomination. Mr. Pope withdrew the motion. Ms. Grady nominated Mr. Dalton to serve as Chair.
13 Mr. Pope seconded the motion. The motion passed unanimously. Mr. Dalton nominated Mr. Cairns to serve as
14 Vice Chair. Mr. Bauer seconded the motion. The motion passed unanimously.

15
16 **MINUTES**

17 Inaugural meeting. There were no minutes.

18
19 **STAFF REPORTS**

20 Mr. Mitchell presented the budget and tax revenue report for the district noting that the total is favorable
21 compared to initial estimates. He said the committee would need to consider whether or not they would like to
22 undertake any economic activity this fiscal year such as a marketing campaign or if they would prefer to wait
23 until more revenue accrues noting that the amount budgeted for expenses is essentially \$23,000. Mr. Mitchell
24 recommended scheduling 90 minutes to cover the balance of both committees for the regularly scheduled
25 meeting on March 28, 2024 and going through the Urban Renewal Plan for the district.

26
27 **SDURDAC CHAIR COMMENTS**

28 Mr. Dalton advised a strategy and vision setting meeting at a future date. The Commission discussed the role of
29 the SDURDAC and how it relates to the URA, the URDAC, and the upcoming Transportation Growth
30 Management mill-site redevelopment project within the district.

31
32 **SDURDAC MEMBER COMMENTS; ROUND TABLE DISCUSSION**

33 There were none.

34
35 **ADJOURNMENT**

36 Mr. Dalton adjourned the meeting at 1:13 PM.

37 Next meeting March 28, 2024

**CITY OF DALLAS
SOUTH DALLAS URBAN RENEWAL DISTRICT
ADVISORY COMMITTEE
STAFF REPORT**

DATE: March 28, 2024
AGENDA ITEM NO.
TOPIC: Budget & tax revenue report
PREPARED BY: Charlie Mitchell
APPROVED BY:
ATTACHMENTS: A. Budget report
B. Urban Renewal Fund

RECOMMENDED ACTION:

N/A – for information only

BACKGROUND:

Attachment A is the budget report for February 2023.

Through the month of February:

- Revenue: \$62,391.11 – property taxes
\$559.73 – interest

\$62,950.84
- Expenses: \$2,915.50 – salaries
\$525.00 – professional services
\$283.71 – misc.

\$3,724.21

SUMMARY TIMELINE:

N/A

FISCAL IMPACT:

N/A

SUGGESTED MOTION:

N/A

Budget Report

For Fiscal: 2023-2024 Period Ending: 02/29/2024

	Original Total Budget	Current Total Budget	Period Activity	Fiscal Activity	Variance Favorable (Unfavorable)	Percent Remaining
Fund: 31 - SOUTH DALLAS URBAN RENEWAL FUND						
Revenue						
State LB Report: 90 - Property Taxes						
31-450-00-4100 CURRENT PROPERTY TAX	30,000.00	30,000.00	286.97	62,391.11	32,391.11	207.97 %
State LB Report: 90 - Property Taxes Total:	30,000.00	30,000.00	286.97	62,391.11	32,391.11	107.97 %
State LB Report: 91 - Resources Except Property Taxes						
31-480-00-4610 INTEREST ON INVESTMENTS	2,000.00	2,000.00	266.73	559.73	-1,440.27	72.01 %
State LB Report: 91 - Resources Except Property Taxes Total:	2,000.00	2,000.00	266.73	559.73	-1,440.27	72.01 %
Revenue Total:	32,000.00	32,000.00	553.70	62,950.84	30,950.84	96.72 %
Expense						
State LB Report: 01 - Personnel Services						
31-310-50-6051 SALARIES	5,500.00	5,500.00	995.21	1,990.42	3,509.58	63.81 %
31-310-50-6061 FRINGE BENEFITS	3,500.00	3,500.00	462.55	925.08	2,574.92	73.57 %
State LB Report: 01 - Personnel Services Total:	9,000.00	9,000.00	1,457.76	2,915.50	6,084.50	67.61 %
State LB Report: 02 - Materials and Services						
31-310-50-6210 MATERIALS AND SUPPLIES	8,000.00	8,000.00	0.00	0.00	8,000.00	100.00 %
31-310-50-6465 PROFESSIONAL SERVICES	8,000.00	8,000.00	525.00	525.00	7,475.00	93.44 %
31-310-50-6600 MISCELLANEOUS	7,000.00	7,000.00	0.00	283.71	6,716.29	95.95 %
State LB Report: 02 - Materials and Services Total:	23,000.00	23,000.00	525.00	808.71	22,191.29	96.48 %
Expense Total:	32,000.00	32,000.00	1,982.76	3,724.21	28,275.79	88.36 %
Fund: 31 - SOUTH DALLAS URBAN RENEWAL FUND Surplus (Deficit):	0.00	0.00	-1,429.06	59,226.63	59,226.63	0.00 %

ATTACHMENT B.

South Dallas Urban Renewal Fund

Revenues

	Actual 2021-22	Actual 2022-23	Amended 2023-24	Proposed 2024-25	Approved 2024-25	Adopted 2024-25
Current taxes	0	0	30,000	65,000		
Delinquent taxes	0	0	0	2,500		
Interest	0	0	2,000	2,000		
Miscellaneous	0	0	0			
Total revenues	0	0	32,000	69,500	0	0
Beginning Balance	0	0	0	0	0	0
TOTAL	0	0	32,000	69,500	0	0

Expenditures

	Actual 2021-22	Actual 2022-23	Amended 2023-24	Proposed 2024-25	Approved 2024-25	Adopted 2024-25
Personnel Services						
Salaries	0	0	5,500	6,500		
Fringe	0	0	3,500	3,500		
Total personnel services	0	0	9,000	10,000	0	0
Materials and Services						
Materials and Supplies	0	0	8,000	10,000		
Professional Services	0	0	8,000	15,000		
Miscellaneous	0	0	7,000	10,000		
Total materials & services	0	0	23,000	35,000	0	0
Capital Outlay						
Projects	0	0	0			
Property Acquisition	0	0	0			
Total capital outlay	0	0	0	0	0	0
Operating Contingencies				24,500		
Total Contingencies	0	0	0	24,500	0	0
TOTAL EXPENDITURES	0	0	32,000	69,500	0	0



**CITY OF DALLAS
SOUTH DALLAS URBAN RENEWAL DISTRICT
ADVISORY COMMITTEE
STAFF REPORT**

DATE: March 28, 2024
AGENDA ITEM NO.
TOPIC: Urban Renewal Plan Walkthrough
PREPARED BY: Tyler Ferrari
APPROVED BY:
ATTACHMENTS: A. Urban Renewal Plan

RECOMMENDED ACTION:

N/A – for information only

BACKGROUND:

The Urban Renewal Plan guides the City of Dallas Urban Renewal agency on the goals and plan for the specified district. Staff will present the attached plan and guide the committee on some key points for them to keep in mind as the district progresses and projects come up for discussion.

SUMMARY TIMELINE:

N/A

FISCAL IMPACT:

N/A

SUGGESTED MOTION:

N/A

South Dallas Urban Renewal Plan

This document remains draft until the City Council adoption of the South Dallas Urban Renewal Plan.

Adopted by the City of Dallas

August 15, 2022

Ordinance No. 1876



If Amendments are made to the Plan, the Resolution or Ordinance Number, date and a brief summary will be listed here. The amendment will be incorporated into the Plan and noted through a footnote.

LIST OF PARTICIPANTS

City Council

Brian Dalton, Mayor
Michael Schilling, Council President
Larry Briggs
Kristen Collins
Terry Crawford
Rod Dunham
Kim Fitzgerald
Bill Hahn
Ken Woods, Jr.

Dallas Development Commission

Brian Dalton
Michael Schilling
Larry Briggs
Kristen Collins
Terry Crawford
Rod Dunham
Kim Fitzgerald
Bill Hahn
Ken Woods, Jr.

Planning Commission

David Shein, Chair
John Swanson, Vice-Chair
Tory Banford

City of Dallas Staff

Brian Latta, City Manager
Charlie Mitchell, Economic & Community Development Director
Gary Marks, Public Works Director
Tom Gilson, Engineering Supervisor
Sam Kaufmann, City Recorder
Lane Shetterly, City Counsel

Consulting Team

Elaine Howard Consulting, LLC

Elaine Howard
Scott Vanden Bos

Tiberius Solutions LLC

Nick Popenuk
Ali Danko
Rob Wyman

Andy Groh

Carol Kowash

John Schulte

This page intentionally left blank

TABLE OF CONTENTS

I.	<u>DEFINITIONS</u>	1
II.	<u>INTRODUCTION</u>	4
III.	<u>MAXIMUM INDEBTEDNESS</u>	6
IV.	<u>PLAN GOALS</u>	7
V.	<u>URBAN RENEWAL PROJECT CATEGORIES</u>	8
VI.	<u>URBAN RENEWAL PROJECTS</u>	9
VII.	<u>AMENDMENTS TO PLAN</u>	10
VIII.	<u>PROPERTY ACQUISITION AND DISPOSITION</u>	11
IX.	<u>RELOCATION METHODS</u>	12
X.	<u>TAX INCREMENT FINANCING OF PLAN</u>	13
XI.	<u>VALIDITY</u>	13
XII.	<u>ANNUAL REPORT</u>	14
XIII.	<u>RELATIONSHIP TO LOCAL OBJECTIVES</u>	16
XIV.	<u>LEGAL DESCRIPTION</u>	26

I. DEFINITIONS

“Agency ” means the Dallas Development Commission. This Dallas Development Commission is responsible for administration of the urban renewal plan.

“Area” means the properties and rights-of-way located within the South Dallas Urban Renewal Boundary.

“Blight” is defined in ORS 457.010(1)(A-E) and identified in the ordinance adopting the urban renewal plan.

“Board of Commissioners” means the Polk County Board of Commissioners.

“City” means the City of Dallas, Oregon.

“City Council” or “Council” means the Dallas City Council.

“Comprehensive Plan” means the City of Dallas comprehensive land use plan and its implementing ordinances, policies, and standards.

“County” means Polk County, Oregon.

“Fiscal year ending” means the year commencing on July 1 of one year and closing on June 30 of the next year.

“Frozen base” means the total assessed value including all real, personal, manufactured, and utility values within an urban renewal area at the time of adoption. The County Assessor certifies the assessed value after the adoption of an urban renewal plan.

“Increment” means that part of the assessed value of a taxing district attributable to any increase in the assessed value of the property located in an urban renewal area, or portion thereof, over the assessed value specified in the certified statement.

“Maximum indebtedness” means the amount of the principal of indebtedness included in a plan pursuant to ORS 457.190 and does not include indebtedness incurred to refund or refinance existing indebtedness.

“ORS” means Oregon Revised Statutes. Chapter 457 specifically relates to urban renewal.

“Planning Commission” means the Dallas Planning Commission.

“Revenue sharing” means under-levying tax increment proceeds to effectively share a portion of the revenue with the other taxing districts that levy permanent rate taxes in the urban renewal area as defined in ORS 457.470.

“Tax increment financing (TIF)” is a method of funding urban renewal projects and programs through incurring debt that is repaid by the division of taxes accomplished through the adoption of an urban renewal plan.

“Tax increment finance revenues” means the funds allocated by the assessor to an urban renewal area due to increases in assessed value over the frozen base within the area.

“UGB” means urban growth boundary.

“Urban renewal area (URA)” means a blighted area included in an urban renewal plan or an area included in an urban renewal plan under ORS 457.160.

“Urban renewal plan” or “Plan” means a plan, as it exists or is changed or modified from time to time, for one or more urban renewal areas, as provided in ORS 457.085, 457.095, 457.105, 457.115, 457.120, 457.125, 457.135 and 457.220.

“Urban renewal project” or “Project” means any work or undertaking carried out under ORS 457 in an urban renewal area.

“Urban renewal report” or “Report” means the official report that accompanies the urban renewal plan pursuant to ORS 457.087.

II. INTRODUCTION

A. Plan Overview

The City of Dallas (Dallas) completed an urban renewal feasibility study in April of 2022. The study indicated that significant tax increment funds could be raised in their proposed urban renewal area to warrant creation of an urban renewal area. The Dallas City Council (City Council) reviewed the feasibility study and instructed staff to proceed with preparation of an urban renewal plan for their consideration.

Opportunities for public involvement included:

- *Briefing for the City Council presentation of the Feasibility Study*
- *Meetings with City Council on March 7, 2021, March 21, 2022, April 4, 2022*
- *Project Survey posted June 7, 2022—through June 19, 2022*
- *Dallas Development Commission - Urban Renewal Agency meeting on June 20, 2022*
- *Planning Commission meeting on July 12, 2022*
- *City Council public hearing on August 1, 2022 which was noticed to all utility customers in the City of Dallas via the utility bills.*
- *City Council 2nd reading and vote on August 15, 2022*

The South Dallas Urban Renewal Plan Area (Area), shown in Figure 1, consists of approximately 423.3 total acres: 374 acres of land in tax lots and 49.3 acres of public rights-of-way. It is anticipated that the Plan will take thirty years of tax increment collections to implement. The maximum amount of indebtedness that may be issued for the Plan is \$41,600,000 (Forty-one Million, Six Hundred Thousand Dollars). Detailed financial analysis is in the Report accompanying the South Dallas Urban Renewal Plan.

Goals and objectives developed for the Plan are intended to guide tax increment finance (TIF) revenue investment in the Area over the life of the Plan. The project category descriptions and list of projects are similarly intended to aid future decision makers when considering how best to expend TIF revenue. The Plan is to be administered by the Dallas Development Commission - Urban Renewal Agency. Substantial amendments to the Plan must be approved by City Council as outlined in Section VII. All amendments to the Plan are to be listed numerically on the inside of the front page of the Plan and then incorporated into the Plan document and noted by footnote with an amendment number and adoption date.

The relationship between the sections of the Plan and the ORS 457.085 requirements is shown in Table 1. The specific reference in the table is the section of this Plan that primarily addresses the statutory reference. There may be other sections of the Plan that also address the statute.

Table 1 - Statutory References

Statutory Requirement	Plan Section
ORS 457.085(2)(a)	V, VI
ORS 457.085(2)(b)	V, VI
ORS 457.085(2)(c)	XIV
ORS 457.085(2)(d)	XIII
ORS 457.085(2)(e)	XIII
ORS 457.085(2)(f)	IX
ORS 457.085(2)(g)	VIII
ORS 457.085(2)(h)	III
ORS 457.085(2)(i)	VII
ORS 457.085(2)(j)	Not applicable

B. Urban Renewal Overview

Urban renewal allows for the use of tax increment financing, a funding source that is unique to urban renewal, to fund its projects. Tax increment revenues - the amount of property taxes generated by the increase in total assessed values in the urban renewal area from the time the urban renewal area is first established - are used to repay borrowed funds. The borrowed funds are used to pay for urban renewal projects and cannot exceed the maximum indebtedness amount set by the urban renewal plan.

The purpose of urban renewal is to improve specific areas of a city that are poorly developed or underdeveloped, called blighted areas in Oregon Revised Statutes (ORS) 457.010. These areas can have deteriorated buildings, changing uses, streets and utilities in poor condition, a complete lack of streets and utilities altogether, or other obstacles to development.

In general, urban renewal projects can include construction or improvement of streets, utilities, and other public facilities; assistance for rehabilitation or redevelopment of property; acquisition and re-sale of property (site assembly) from willing sellers; and

improvements to public spaces. This Area meets the definition of blight due to the condition of the buildings, changing uses in the Area, utility infrastructure deficiencies, and underdeveloped and undeveloped properties. These blighted conditions are specifically cited in the ordinance adopting the Plan and described in detail in the Report.

The Report contains the information required by ORS 457.087, including:

- A description of the physical, social, and economic conditions in the area;
- Expected impact of the Plan, including fiscal impact in light of increased services;
- Reasons for selection of the Plan area;
- The relationship between each project to be undertaken and the existing conditions;
- The estimated total cost of each project and the source of funds to pay such costs;
- The estimated completion date of each project;
- The estimated amount of funds required in the Area and the anticipated year in which the debt will be retired;
- A financial analysis of the Plan;
- A fiscal impact statement that estimates the impact of tax increment financing upon all entities levying taxes upon property in the area; and
- A relocation report.

III. MAXIMUM INDEBTEDNESS

Maximum indebtedness is the amount of indebtedness secured by a pledge of tax increment revenue that can be spent on projects, programs and administration throughout the life of the Plan. The maximum amount of indebtedness that may be issued or incurred under the Plan, based upon good faith estimates of the scope and costs of projects in the Plan and the schedule for their completion is \$41,600,000 (Forty-one Million, Six Hundred Thousand Dollars). This amount is the principal of such indebtedness and does not include interest or indebtedness incurred to refund or refinance existing indebtedness or interest earned on bond proceeds.

IV. PLAN GOALS

The goals of the South Dallas Urban Renewal Plan are listed below. The urban renewal plan is an implementation tool to enable the city to undertake projects for which there are no other funding sources or are limited funding sources.

The goals of the Plan represent its basic intents and purposes. The urban renewal projects identified in Sections V and VI of the Plan are the specific means of meeting the goals. The goals will be pursued as economically as is feasible and at the discretion of the Dallas Development Commission - Urban Renewal Agency . The goals are not listed in any order of importance or priority. A matrix of how the projects align with the goals is shown in Table 2.

- A. Provide tax base diversification by facilitating new and larger commercial and industrial development opportunities
- B. Assist job-creating development with appropriate incentives and partnerships
- C. Add additional commercial zoning to address deficit in commercially-zoned land
- D. Facilitate development of the former Mill Site and other undeveloped or underdeveloped industrial land in south Dallas
- E. Create new employment and commerce opportunities for Dallas residents; encourage more residents to work and shop locally as opposed to commuting to Salem
- F. Improve the infrastructure (transportation, water, wastewater, storm drainage) in the area
- G. Improve the visual appeal of the area to attract more investment
- H. Leverage private-sector capital through creative partnerships
- I. Protect and enhance the environment, notably the Ash Creek corridor

Table 2 – Relationship of Projects to South Dallas Urban Renewal Plan Goals

Project Category	
Public Infrastructure, facilities & planning	A,B,C,D,E,F,G,H,I
Private sector/ economic development	A,B,C,D,E,F,G,H,I
Administration & staffing	A,B,C,D,E,F,G,H,I

V. URBAN RENEWAL PROJECT CATEGORIES

The projects within the Area fall into the following categories.

- A. Public infrastructure, facilities & planning
- B. Private sector/ economic development
- C. Administration & staffing

Figure 1 – South Dallas Urban Renewal Plan Area Boundary

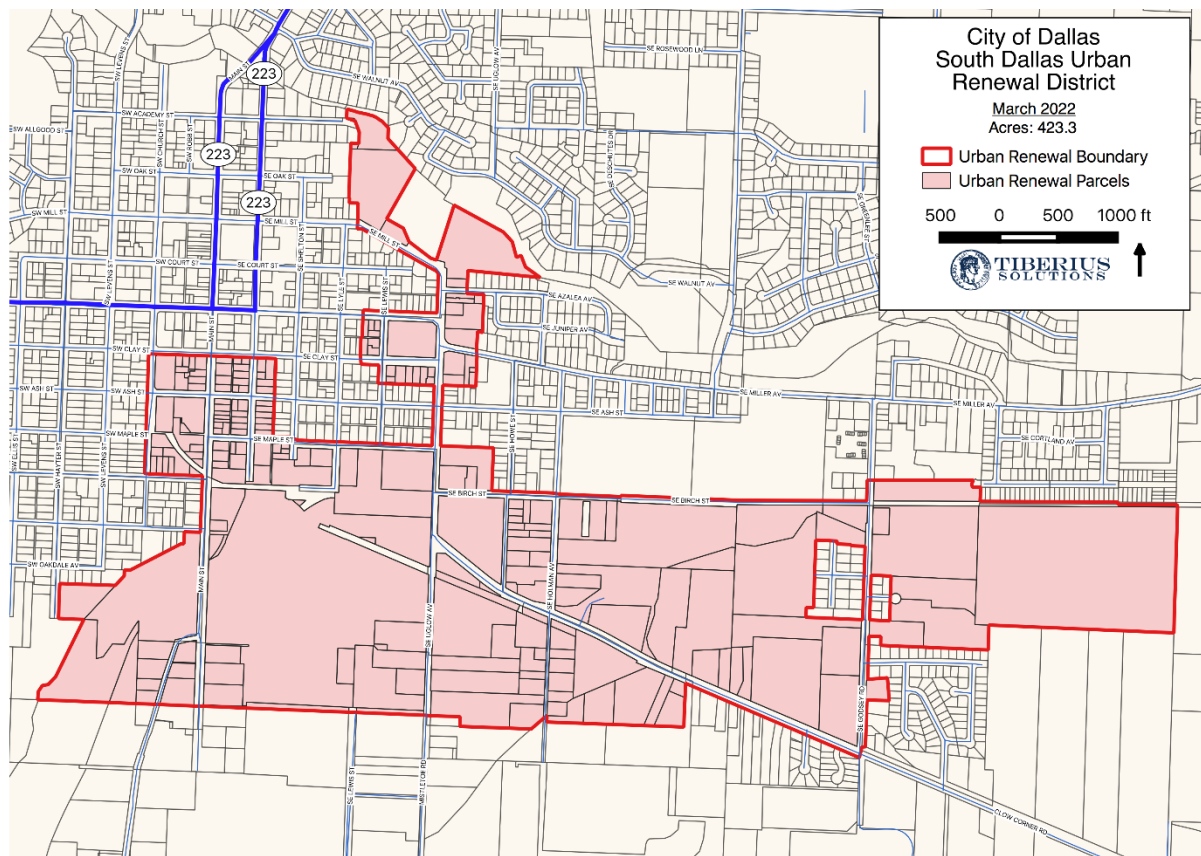

Source: Tiberius Solutions

VI. URBAN RENEWAL PROJECTS

Urban renewal projects authorized by the Plan are described below. They are not listed in any priority order. The Dallas Development Commission - Urban Renewal Agency will determine the order of the projects and may add and remove projects in the future through the amendment process defined in Section VII of this Plan. The projects identified for the Area are described below, including how they relate to the existing conditions in the Area.

A. Public infrastructure, facilities & planning

1. Floodway study (Mill Site/ N. Fork Ash Creek)
2. Monmouth Cutoff Road, Uglow Street improvements (from eastern City limits to intersection; may include new intersection; build to City urban design standards)
3. Mill Site transportation improvements (new east-west transportation corridors through the current Mill Site)
4. Jefferson Street/Main Street couplet improvements to the south to connect into current Mill Site area
5. Ash Creek improvements (a portion of the creek lies underneath the Mill Site)
6. Other area roadway, pedestrian, bicycle & rail improvements throughout Area
7. Area water service extensions where needed
8. Area sanitary sewer service upgrades & extensions where needed
9. Purple pipe development (recycled wastewater for industrial uses)
10. Trails systems improvements & extensions, potentially along Ash Creek and at the south end of the current Mill Site

B. Private sector/ economic development

1. Site certification assistance (State of Oregon industrial site certification program)
2. New & existing business assistance programs
3. City fee & Systems Development Charges (SDC) waiver assistance for targeted businesses
4. Targeted commercial marketing
5. Targeted Mill Site improvements

C. Administration & staffing

Authorizes expenditures for the administrative costs associated with managing the Area including budgeting and annual reporting, planning and the implementation of projects in the Area.

VII. AMENDMENTS TO PLAN

The Plan may be amended as described in this section. Adding other properties to the Developer Incentives Program does not require an amendment to the Plan.

A. Substantial Amendments

Substantial Amendments, in accordance with ORS 457.085(2)(i), shall require the same notice, hearing, and approval procedure required of the original Plan, under ORS 457.095, including public involvement, consultation with taxing districts, presentation to the Dallas Development Commission - Urban Renewal Agency, the Planning Commission, the County, and adoption by the City Council by non-emergency ordinance after a hearing. Notice of such hearing shall be provided to individuals or households within the City of Dallas, as required by ORS 457.120. Notice of adoption of a Substantial Amendment shall be provided in accordance with ORS 457.095 and 457.115.

Substantial Amendments are amendments that:¹

1. Add land to the urban renewal area, except for an addition of land that totals not more than a cumulative 1% of the existing area of the urban renewal area; or
2. Increase the maximum amount of indebtedness that can be issued or incurred under the Plan.

B. Minor Amendments

Minor Amendments are amendments that are not Substantial Amendments as defined in this Plan and in ORS 457. Minor Amendments require approval by the Dallas Development Commission - Urban Renewal Agency by resolution.

C. Amendments to the *Dallas Comprehensive Plan* and/or *Dallas Development Code*

Amendments to the *Dallas Comprehensive Plan* and/or *Dallas Development Code* that affect the Plan and/or the Area shall be incorporated automatically within the Plan without any separate action required by the Dallas Development Commission - Urban

¹ Unless otherwise permitted by state law, no land equal to more than 20 percent of the total land area of the original Plan shall be added to the urban renewal area by amendments, and the aggregate amount of all amendments increasing the maximum indebtedness may not exceed 20 percent of the Plan's initial maximum indebtedness, as adjusted, as provided by law and by concurrence provisions in ORS 457.470.

Renewal Agency or City Council. If a Substantial Amendment is prepared, the Section of this Plan on Relationship to Local Objectives should be updated.

VIII. PROPERTY ACQUISITION AND DISPOSITION

The Plan authorizes the acquisition and disposition of property as described in this section. Property includes any and all interests in property, including fee simple ownership, lease, easements, licenses, or other rights to use. If property is acquired it will be identified in the Plan through a Minor Amendment, as described in Section VII. Identification of property to be acquired and its anticipated disposition is required by ORS 457.085(g). If property acquisition includes a public building, how that public building serves and benefits the Area must be identified per ORS 457.085(2)(j).

A. Property acquisition for public improvements

The Dallas Development Commission - Urban Renewal Agency may acquire any property within the Area for the public improvement projects undertaken pursuant to the Plan by all legal means, including use of eminent domain. Good faith negotiations for such acquisitions must occur prior to institution of eminent domain procedures.

B. Property acquisition from willing sellers

The Plan authorizes Dallas Development Commission - Urban Renewal Agency acquisition of any interest in property within the Area that the Dallas Development Commission - Urban Renewal Agency finds is necessary for private redevelopment, but only in those cases where the property owner wishes to convey such interest to the Dallas Development Commission - Urban Renewal Agency. The Plan does not authorize the Dallas Development Commission - Urban Renewal Agency to use the power of eminent domain to acquire property from a private party to transfer property to another private party for private redevelopment. Property acquisition from willing sellers may be required to support development of projects within the Area.

C. Land disposition

The Dallas Development Commission - Urban Renewal Agency will dispose of property acquired for a public improvement project by conveyance to the appropriate public Dallas Development Commission - Urban Renewal Agency responsible for the construction and/or maintenance of the public improvement. The Dallas Development Commission - Urban Renewal Agency may retain such property during the construction of the public improvement.

The Dallas Development Commission - Urban Renewal Agency may dispose of property acquired under Subsection B of this Section VIII by conveying any interest in property acquired. Property shall be conveyed at its fair reuse value. Fair reuse value is the value, whether expressed in terms of rental or capital price, at which the urban

renewal Dallas Development Commission - Urban Renewal Agency , in its discretion, determines such land should be made available in order that it may be developed, redeveloped, cleared, conserved, or rehabilitated for the purposes specified in the Plan. Because fair reuse value reflects limitations on the use of the property to those purposes specified in the Plan, the value may be lower than the property's fair market value.

Where land is sold or leased, the purchaser or lessee must agree to use the land for the purposes designated in the Plan and to begin and complete the building of its improvements within a period of time that the Dallas Development Commission - Urban Renewal Agency determines is reasonable.

D. Properties to be acquired

This Plan must provide an indication of which real property may be acquired and the anticipated disposition of said real property whether by retention, resale, lease or other legal use, together with an estimated time schedule for such acquisition and disposition. This may be added at a date when the property is identified and may be added through a Minor Amendment.

IX. RELOCATION METHODS

When the Dallas Development Commission - Urban Renewal Agency acquires occupied property under the Plan, residential or commercial occupants of such property shall be offered relocation assistance, as required under applicable state law. Prior to such acquisition, the Dallas Development Commission - Urban Renewal Agency shall adopt rules and regulations, as necessary, for the administration of relocation assistance. The Dallas Development Commission - Urban Renewal Agency will comply with all applicable state law in providing these potential benefits.

There are plans to acquire land for infrastructure which may trigger relocation benefits in the future in the Area. All acquisitions will be reviewed for potential of relocation benefits.

X. TAX INCREMENT FINANCING OF PLAN

Tax increment financing consists of using annual tax increment revenues to make payments on debt, usually in the form of bank loans or revenue bonds. The proceeds of the debt are used to finance the urban renewal projects authorized in the Plan. Debt may be either long-term or short-term.

Tax increment revenues equal most of the annual property taxes imposed on the cumulative increase in assessed value within an urban renewal area over the frozen base value (i.e., total assessed value at the time an urban renewal plan is adopted). The property taxes for general obligation (GO) bonds and local option levies approved after October 6, 2001, are not part of the tax increment revenues.

A. General description of the proposed financing methods

The Plan will be financed using a combination of revenue sources. These include:

- Tax increment revenues;
- Advances, loans, grants, and any other form of financial assistance from federal, state, or local governments, or other public bodies;
- Loans, grants, dedications, or other contributions from private developers and property owners, including, but not limited to, assessment districts; and
- Any other public or private source.

Revenues obtained by the Dallas Development Commission - Urban Renewal Agency will be used to pay or repay the costs, expenses, advancements, and indebtedness incurred in (1) planning or undertaking project activities, or (2) otherwise exercising any of the powers granted by ORS Chapter 457 in connection with the implementation of this Plan, including costs associated with the preparation of the Plan.

B. Tax increment financing

The Plan may be financed, in whole or in part, by tax increment revenues allocated to the Dallas Development Commission - Urban Renewal Agency, as provided in ORS Chapter 457. The ad valorem taxes, if any, levied by a taxing district in which all or a portion of the Area is located, shall be divided as provided in Section 1c, Article IX of the Oregon Constitution, and ORS 457.440. Amounts collected pursuant to ORS 457.440 shall be deposited into the unsegregated tax collections account and distributed to the Dallas Development Commission - Urban Renewal Agency based upon the distribution schedule established under ORS 311.390.

XI. VALIDITY

Should a court of competent jurisdiction find any work, clause, sentence, section or part of this Plan to be invalid, the remaining words, clauses, sentences, sections or parts shall be unaffected by such findings and shall remain in full force and effect for the duration of this Plan.

XII. ANNUAL REPORT

The Dallas Development Commission - Urban Renewal Agency shall file an Annual Financial Statement in compliance with ORS 457.460.

Figure 2 - Comprehensive Plan Designations

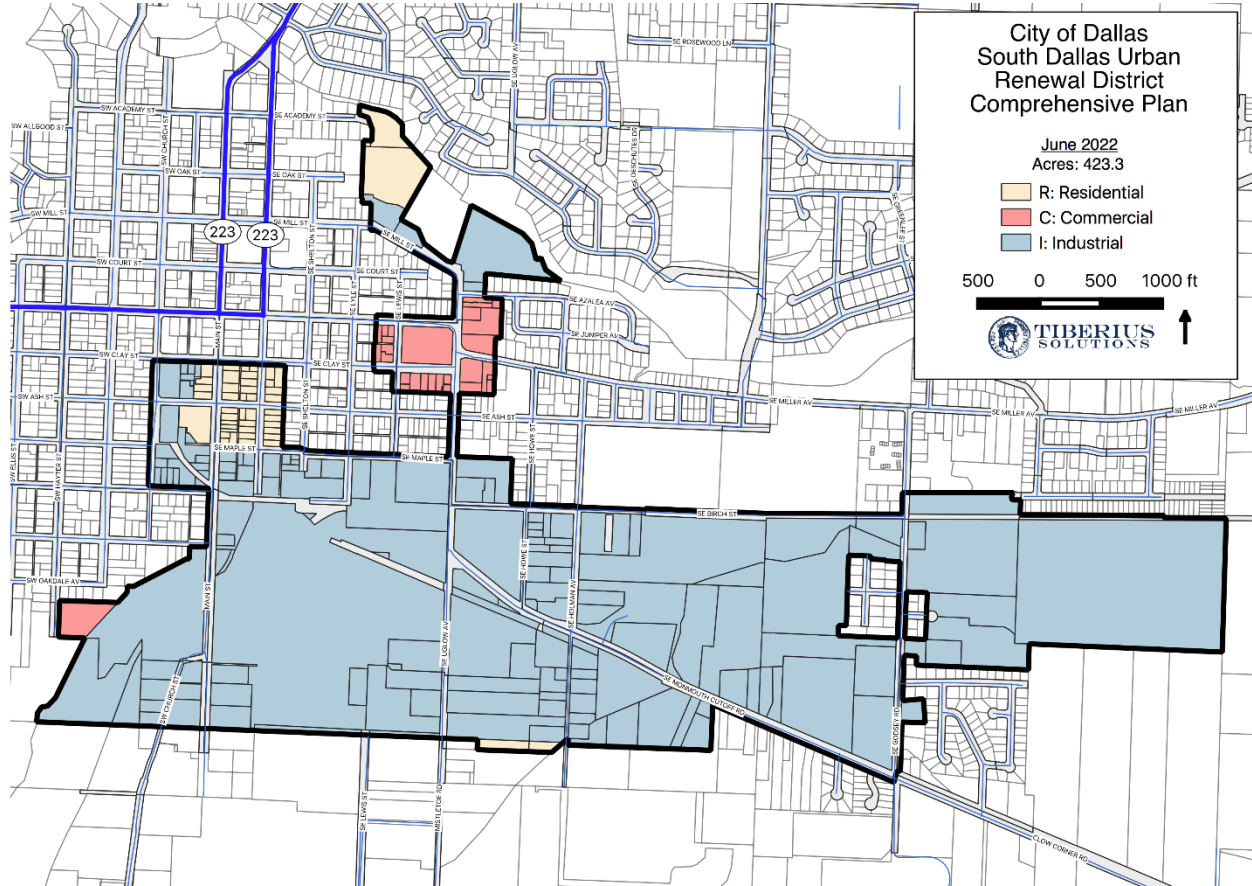

Source: Tiberius Solutions

Figure 3 – Zoning Designations

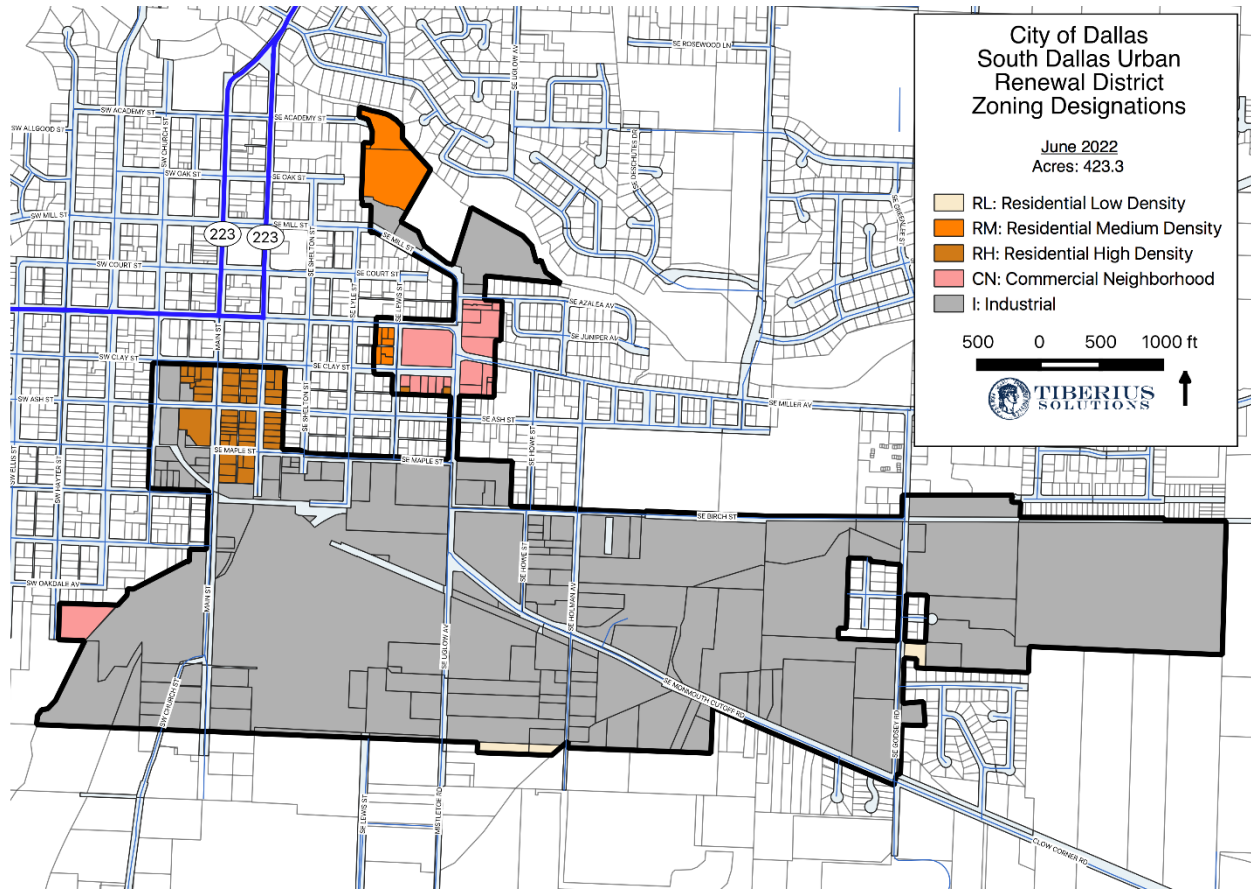

Source: Tiberius Solutions

XIII. RELATIONSHIP TO LOCAL OBJECTIVES

ORS 457.085 requires that the Plan conform to local objectives including the comprehensive plan and economic development plan of a locality. This section provides that analysis. Relevant local planning and development objectives are contained within the *City of Dallas Comprehensive Plan (Comprehensive Plan)*, *Dallas Transportation System Plan*, *Dallas Economic Opportunity Analysis*, *Dallas Housing Needs Analysis*, *Dallas Parks Master Plan*, and the *Dallas Development Code*. The following section describes the purpose and intent of these plans, the main applicable goals and policies within each plan, and an explanation of how the Plan relates to the applicable goals and policies. The analysis covers the most relevant sections of the documents but may not cover every section of the documents that relate to the Plan.

The numbering of the goals and policies within this section reflects the numbering that occurs in the original document. *Italicized text* is text that has been taken directly from an original document and therefore cannot be changed.

Comprehensive Plan and Zoning designations for all land in the Area are shown in Figure 2. All proposed land uses conform to Figure 2. Maximum densities and building requirements for all land in the Area are contained in the Dallas Development Code.

A. City of Dallas Comprehensive Plan

The Dallas Comprehensive Plan is the controlling land use document for the City and its Urban Growth Boundary (UGB). From a land use perspective, the comprehensive plan is like a state or federal constitution: it provides the legal framework and long-term vision for implementing plans and land use regulations. The Dallas Comprehensive Plan has been found by the Land Conservation & Development Commission (LCDC) to comply with the 14 applicable “Statewide Planning Goals,” which are, in effect, state planning requirements that must be met by each city and county in Oregon.

As the Comprehensive Plan is updated in the future, this document will automatically incorporate those updates without the Plan having to be formally amended. This section of the Plan should be updated if there is a substantial amendment completed in the future.

Plan Details

Chapter 1: Citizen Involvement

GOAL STATEMENT:

To Ensure Meaningful Citizen Involvement and Participation In the Land Use Planning Process

1.1 Two Way Communication

To provide mechanisms which will promote effective two-way communication between citizens and the policy/decision makers.

1.2 Citizen Influence

To provide citizens an opportunity to be involved in the planning process.

1.3 Technical Information

To ensure that all documents and information which will assist citizens in effectively participating in the planning process are available to the public in an understandable form subject to the requirements of state and local laws.

1.4 Feedback Mechanisms

To ensure that the governing bodies will respond to citizens land use planning questions and concerns.

Finding: There was a Feasibility Study completed for this urban renewal plan during which there were three city council meetings. There was a virtual Open House from June 7-June 19th on the city website to provide information and gain feedback on projects to be undertaken in the Area. There was a Dallas Development Commission - Urban Renewal Agency (Agency) meeting on June 20, 2022, Planning Commission meeting on July 12, 2022, City Council public hearing on August 1, 2022 which was noticed to all utility customers in the City of Dallas and a City Council 2nd reading and vote on August 15, 2022. The Plan is in conformance with Chapter 1: Citizen Involvement of the *Dallas Comprehensive Plan*.

Chapter 2: A Sustainable Dallas Economy

Economic Goals

The City's overall economic goal is to continue as a sustainable community in order to enhance the quality of life for all Dallas citizens. This goal is best achieved by increasing economic opportunities without threatening environmental quality or eroding the region's natural resource base

A. Maintain the existing and encourage the future development of a sound economic base in Dallas by providing for adequate and diversified industries, retail and wholesale establishments and service related industries.

B. Encourage new industrial development that serves the needs of the Dallas community and is designed to minimize impacts on Dallas residential neighborhoods, consistent with the policies of the Dallas Comprehensive Plan.

C. Maintain the Central Business District as the dominant commercial and cultural center of the community.

D. Encourage a broad variety of commercial activities in the Dallas area in convenient and desirable locations to serve the public.

E. Provide for small-scale, neighborhood commercial centers that complement the Central Business District and which minimize routine travel from home to shopping.

Economic Policies

2.1 Industrial Development Policies

1. Encourage the future development of industrial facilities, primarily ones that would have a limited environmental effect upon the community and which do not place excessive demands on the City's infrastructure.

2. Require all existing and future industries to locate within the City Limits and to conform to existing federal and state environmental laws.

3. Encourage the diversification of industries in Dallas to reduce the chance of economic depression because of an economic slump in one industry.

4. Encourage the development of an industrial or business park within the Dallas City Limits.

5. Provide for a choice among suitable industrial and business park sites.

6. Encourage the development of agriculture-related industries

2.2 Manpower Development Policies

*3. Encourage the creation of job opportunities for **residents** in the Dallas area within new and present businesses and industries.*

Finding: There are two main project categories in the Plan, both with the intention of creating new economic activity for Dallas: Public infrastructure, facilities & planning and Private sector/ economic development. The Public Infrastructure, facilities & planning is to help provide the improvements necessary for development to occur in the Area. The Private sector/ economic development is to provide support for bringing in the new

development to provide jobs for the Dallas community. The Plan is in conformance with Chapter 2: A Sustainable Economy of the *Dallas Comprehensive Plan*. .

Chapter 3: Livable Residential Neighborhoods

Residential Neighborhood Goals

A. To maintain and enhance the quality of existing residential neighborhoods and, through master planning, to ensure that new development is integrated into the community and results in new, high quality residential neighborhoods.

B. To encourage the development of a variety of housing types and densities to meet the needs and desires of the community, and assure that existing and future residents of the community have the opportunity to acquire safe and sanitary housing at reasonable cost.

Finding: The Plan will provide infrastructure to serve the Area. This infrastructure will support any development in the Area that can be developed under the zoning code. There are both medium density residential and high density residential zoned properties within the Area. The Plan is in conformance with Chapter 3: Livable Residential Neighborhoods of the Dallas Comprehensive Plan.

Chapter 4 Parks & Open Space

To conserve and protect the community's natural and scenic resources and to ensure that new development helps to provide for the outdoor recreational needs of its residents

1. A riparian buffer shall be established and protected along Rickreall and Ash Creeks, as prescribed in the Dallas Development Code. This undisturbed area shall be surveyed and

protected through deed restrictions or other appropriate means, prior to development approval.

2. Dallas will encourage the development of an integrated trail system to provide recreational opportunities and to link open space and park areas through the planned development process.

3. Rickreall and Ash Creeks shall be protected from pollution.

Finding: There are projects in the Plan for Ash Creek improvements, trail systems improvements and extensions potentially along Ash Creek and at the south end of the

current Mill Site. The Plan is in conformance with Chapter 4: Parks & Open Space of the *Dallas Comprehensive Plan*.

Chapter 7: Public Facilities Plan

Public Facilities Goal

To provide a timely, orderly and efficient arrangement of public facilities and services to serve as a framework for community development.

7.1.2 Sanitary Sewer System Policies

- 1. All new construction within the UGB shall be required to connect to the City's sanitary sewer system as lands are annexed to the City.*
- 2. Dallas shall continue to make improvements to the City's sewage treatment plant necessary to support population increases as projected in the Dallas Comprehensive Plan and supporting Master Sewer Plan.*
- 3. Dallas shall continue to separate combined storm and sanitary sewers and shall actively pursue a program of rehabilitation and maintenance of the existing collector system.*

7.1.3 Water System Policies

- 1. All new construction within the UGB shall be required to connect to the City's water system as lands are annexed to the City.*
- 2. Dallas shall continue to make improvements to the City's water treatment plant and storage facilities necessary to support population increases as projected in the Dallas Comprehensive Plan and supporting Master Water Plan.*

7.1.4 Storm Drainage System Policies

- 1. All new development shall be designed consistent with the City's long-range storm water management plans and programs, and shall only occur consistent with the following provisions:*
 - a) Off-site drainage impacts shall be controlled through appropriate design.*
 - b) Stream channels and wetlands shall be protected through setbacks and other appropriate mechanisms.*

c) Erosion and sediment controls for excavation, new development and re-development projects shall be required.

Finding: There are projects in the Plan for a floodway study, water extensions, sanitary sewer extensions, and purple pipe development within the Area. The Plan is in conformance with Chapter 7: Public Facilities Plan of the *Dallas Comprehensive Plan*.

TRANSPORTATION (TSP p 2-13)

GOALS

Transportation Goal

To develop a balanced and safe transportation system that minimizes community disruption and promotes the economic and energy-efficient movement of goods and people around and through the community.

Circulation System Policies

- 1. The City's transportation system should be fully integrated into the regional and state transportation system.*
- 3. The transportation system shall provide adequate access to all planned land uses and shall:*
 - Focus on direct multi-modal access to business districts.*
 - Achieve a balanced traffic flow through each section of the City.*
 - Reduce congestion on arterial streets by providing alternative transportation routes.*
- 6. A system of bicycle and pedestrian facilities should be fully integrated into the transportation system.*

Bicycle and Pedestrian Transportation Policies

- 1. To accommodate the bicyclist and pedestrian now and during the planning period, the City shall plan for bicycle and pedestrian facilities and integrate them into the street circulation system.*
- 5. Facilities providing safe and convenient pedestrian and bicycle access within and from new subdivisions, planned developments, shopping centers, and industrial parks to nearby residential areas, transit stops and neighborhood*

activity centers, such as schools, parks and shopping shall be required. This shall include:

A. Sidewalks along arterials and collectors

- Bikeways as provided in the Bicycle and Pedestrian Plan*
- Areas and developments identified in this policy should be connected with separate bike or pedestrian ways, where appropriate to minimize travel distance*

Finding: There are transportation projects in the Plan for improvements to roads, bikeways pedestrian and rail improvements, and Mill Site transportation improvements within the Area. The Plan is in conformance with the Transportation Systems Plan of the *Dallas Comprehensive Plan*.

Overall Finding: There are projects in the Plan that implement the *Dallas Comprehensive Plan*. Therefore, the Plan conforms to the *City of Dallas Comprehensive Plan*.

B. Dallas Parks Master Plan

The 2015 Dallas Parks Master Plan provides a 20-year vision for development, maintenance, and operation of the City of Dallas's entire park system.

The comprehensive plan articulates the community's vision to provide healthy and enjoyable recreational opportunities to its residents and visitors. This Plan provides specific tools and guidance for achieving the goals and specific action items envisioned by City staff and the community at large.

Vision Statement

The City of Dallas provides a well-maintained parks and trails system that promotes healthy lifestyles, encourages use by people of all ages and abilities, and connects the community to its natural surroundings.

Goals

Goal 1- Future Parkland Identification: Identify areas within the urban growth boundary for strategic expansion of the Dallas Parks System.

Goal 5- Natural Areas: Promote and enhance natural areas to allow access and protect ecosystems.

Goal 7- Connectivity: Increase connectivity for biking, walking, and running throughout the trail system.

Goal 9- Funding: Identify long-term funding sources for the maintenance and expansion of the Dallas Parks System.

Finding: There are projects in the Plan for Ash Creek improvements, trail systems improvements and extensions potentially along Ash Creek and at the south end of the current Mill Site. The Plan is in conformance with the *Dallas Parks Master Plan*.

C. Dallas Economic Opportunity Analysis

An Economic Needs Analysis was completed by ECONorthwest in 2021. The ENA identified the following issues for industrial development within Dallas.

Encourage property owners to get sites certified as development ready through Business Oregon’s Certified Shovel Ready program, to demonstrate that utilities are available to serve sites at volume and capacity able to accommodate target industries.

Coordinate capital improvement planning to ensure infrastructure availability on industrial land and continue to pursue funding for needed infrastructure to support economic development activities.

Finding: The *Dallas Economic Opportunity Analysis* identified specific actions to improve the economy in Dallas. Providing for the infrastructure and incentives to assist in the development of the industrial and commercial lands is in conformance with the *Dallas Economic Opportunity Analysis*.

D. Dallas Housing Needs Analysis

The Dallas Housing Needs Analysis was completed in June of 2019 with final City Council action on March 16, 2020.

The buildable residential land within the Dallas UGB as currently planned is sufficient to meet future housing demand for the low and high-density housing types, but would require additional policy measures to address medium density housing demand.

Finding: The *Dallas Housing Needs Analysis* identified the housing needs in Dallas. The projects identified in the Plan will provide improved utilities and an improved transportation network, increased jobs and recreational activities which will provide support for the provision of housing in Dallas.

E. Dallas Development Code

The land uses in the Area will conform to the zoning designations in the *Dallas Development Code* including the maximum densities and building requirements and are incorporated by reference herein. They are listed in the order that they occur in the ordinance. The verbiage that comes directly from the *Dallas Development Code* is in *italics*. The existing zoning is shown in Figure 2.

The *Dallas Development Code* is intended to implement the City of *Dallas Comprehensive Plan* and related plans and policies in a manner that protects the health, safety, and general welfare of the citizens of Dallas. As the *Dallas Development Code* is updated, this document will be automatically updated. If a substantial amendment is completed in the future, this section will be updated to match the current zoning designations.

Chapter 2.2 Residential Districts

2.2.10 Purpose And Applicability

- A. *Purpose. The Residential Districts are intended to promote the livability, stability and improvement of the City's neighborhoods, while accommodating development of needed housing types at a range of densities, including attached and detached housing, multiple family housing, senior housing, manufactured and site-built housing, group housing, and other special needs housing. The Residential Districts also accommodate parks, schools, places of worship, and other services that are necessary to serve and create complete neighborhoods.*
- B. *Applicability. Residential land use districts or zones are applied in accordance with the policies and Land Use Map contained in the City of Dallas Comprehensive Plan. See Table 2.2.010A. The district standards are based on the following principles:*
 - 1. *Promote the orderly development and improvement of Dallas's neighborhoods, while maintaining and enhancing the community's historic character and traditional neighborhood development patterns.*
 - 2. *Make efficient use of land and public services and implement the Comprehensive Plan.*
 - 3. *Designate land for the range of housing types and densities needed by the community, including owner-occupied, rental housing, and special needs housing.*
 - 4. *Provide flexible lot standards that encourage a mixture of compatible land uses, efficiency in site design, and environmental compatibility.*

5. *Provide for compatible building and site design at an appropriate scale; provide standards that are in character with the built and natural environment of Dallas.*
6. *Apply the minimum amount of regulation necessary to ensure compatibility with existing residences, schools, parks, transportation facilities, and neighborhood services.*
7. *Reduce reliance on the automobile for neighborhood travel and provide options for multiple modes of travel, including walking, bicycling and transit.*

C. *Residential Districts*

Residential Medium. *The Residential Medium (RM) district accommodates detached single family homes on small lots and small-scale multi-family housing, such as duplexes and townhomes, at densities between 6 and 12 dwelling units per acre under the base development standards of the district, and up to 16 dwelling units per acre where Low-Impact Development Incentives are met. Parks, schools, and other civic and institutional uses are also allowed.*

Residential High. *The Residential High (RH) district accommodates a mix of housing types at densities between 10 and 25 dwelling units per acre. Parks, schools and other civic and institutional uses are also allowed.*

Chapter 2.3 Commercial Districts

2.3.010 Purpose and Applicability

This Chapter provides three commercial districts to accommodate the range of commercial land uses in the community.

A. *Overall Intent.*

1. *Promote efficient use of land and urban services;*
2. *Create a mixture of land uses that encourages employment and housing options in close proximity to one another;*
3. *Provide formal and informal community gathering places and opportunities for socialization (i.e., along an active street front);*
4. *Integrate land use, urban design, and transportation to create places that accommodate multiple modes of transportation, including walking,*

bicycling, and transit; support pedestrian-oriented development with appropriate building and site design standards;

- 5. Create a distinct storefront character that is scaled to the applicable land use district;*
- 6. Provide connections to and appropriate transitions between neighborhoods and commercial employment centers;*
- 7. Provide for visitor accommodations and tourist amenities;*
- 8. Manage off-street parking supply and demand to promote compact development patterns and to reduce reliance on the automobile; and*
- 9. Maintain and improve the livability and aesthetics of Dallas's commercial areas by establishing design standards for open space (civic space), landscaping, and architecture.*

B. Purpose of Individual Districts.

c. The Commercial Neighborhood (CN) District applies to limited commercial areas that primarily serve the immediate, surrounding neighborhood. It provides neighborhood goods and services at a smaller scale than the Commercial General District and is focused at designated arterial crossroads locations.

C. Applicability. The land use districts (zones) are as designated on the City of Dallas Zoning Map. Changes to the Zoning Map are applied in accordance with the policies and Land Use Map contained in the City of Dallas Comprehensive Plan. See Table 2.3.020A Allowed Land Uses and Building Types. The specific land use categories are described and uses are defined in Chapter 1.3

Chapter 2.4 Industrial Districts

2.4.010 Purpose

Chapter 2.4 accommodates a range of industrial and employment intensive land uses. The Industrial (I) district is intended to provide for land use compatibility while providing a high-quality environment for a wide range of businesses. The Industrial district also provides suitable locations for heavy industrial uses (e.g., raw materials processing; and manufacturing, assembly, packaging or distribution of heavy or large goods) that would not otherwise be compatible in other districts. Chapter 2.4 guides the orderly development of industrial areas based on the following objectives:

- A. Provide for efficient use of land and public services;*

- B. Provide appropriately zoned land with a range of parcel sizes for industry;*
- C. Provide transportation options for employees and customers;*
- D. Locate business services close to major employment centers;*
- E. Ensure compatibility between industrial uses and nearby commercial and residential areas;*
- F. Provide appropriate design standards to accommodate a range of industrial users; and*
- G. Provide attractive locations for business to locate*

Finding: The Plan conforms with the *Dallas Development Code* as the projects will support the development of parcels in the Area and those parcels will be developed in accordance with the *Dallas Development Code* through the normal City of Dallas development review process.

XIV. LEGAL DESCRIPTION

(WE WILL ADD IN AFTER AKS REVIEWS WITH THE COUNTY)

EXHIBIT A

City of Dallas Urban Renewal Area Description

A tract of land and road rights-of-way, located in the Southeast One-Quarter of Section 32, the Northeast, Northwest, Southwest, and Southeast One-Quarters of Section 33, the Southwest and Southeast One-Quarters of Section 34, Township 7 South, Range 5 West, the Northwest One-Quarter of Section 3, the Northeast and Northwest One-Quarters of Section 4, and the Northeast One-Quarter of Section 5, Township 8 South, Range 5 West, Willamette Meridian, City of Dallas, Polk County, Oregon, and being more particularly described as follows:

Beginning at the northeast corner of the plat “Angor Mobile Home Subdivision, Phase 2”, Polk County Plat Records (Assessor’s Map 8.5.3BB);

1. Thence along the north line of said plat and the north line of the plat “English Addition”, Volume 6, Page 28, Polk County Plat Records, Westerly 915 feet, more or less, to the east line of Parcel 1 of Partition Plat No. 1992-0041, Polk County Plat Records (Assessor’s Map 7.5.34CC);
2. Thence along said east line and the east line of Document Number 2004-004543, Polk County Deed Records, Northerly 75 feet, more or less, to the north line of said Deed Document Number 2004-004543 (Assessor’s Map 7.5.34CC);
3. Thence along said north line, Westerly 100 feet, more or less, to the east right-of-way line of SE Godsey Road (Assessor’s Map 7.5.34CC);
4. Thence along said east right-of-way line, Southerly 368 feet, more or less, to the south line of said plat “English Addition” (Assessor’s Map 8.5.3BB);
5. Thence along said south line, Easterly 169 feet, more or less, to the west line of the plat “Angor Mobile Home Subdivision”, Volume 9, Page 19, Polk County Plat Records (Assessor’s Map 8.5.3BB);
6. Thence along said west line, Southerly 196 feet, more or less, to the north line of Partition Plat No. 2003-0024, Polk County Plat Records (Assessor’s Map 8.5.3BB);
7. Thence along said north line, Westerly 190 feet, more or less, to said east right-of-way line of SE Godsey Road (Assessor’s Map 8.5.3BB);
8. Thence along said east right-of-way line, Southerly 399 feet, more or less, to the northeasterly right-of-way line of Clow Corner Road and the City of Dallas city limits line (Assessor’s Map 8.5.3BB);
9. Thence along said city limits line, Northwesterly 33 feet, more or less (Assessor’s Map 8.5.4AA);
10. Thence continuing along said city limits line, Southerly 107 feet, more or less, to the intersection of the west right-of-way line of SE Godsey Road and the southwesterly right-of-way line of SE Monmouth Cutoff (Assessor’s Map 8.5.4AA);
11. Thence along said southwesterly right-of-way line, Northwesterly 1,606 feet, more or less, to the northerly west line of Document Number 2014-000611, Polk County Deed Records (Assessor’s Map 8.5.4AB);

12. Thence along said northerly west line, Southerly 360 feet, more or less, to the City of Dallas city limits line (Assessor's Map 8.5.4AB);
13. Thence along said city limits line, Westerly 1,214 feet, more or less, to the northwesterly line of Parcel 2 of Document Number 2003-021494, Polk County Deed Records (Assessor's Map 8.5.4BA);
14. Thence along said northwesterly line, Southwesterly 112 feet, more or less, to the easterly extension of the south line of Partition Plat No. 1992-0017, Polk County Plat Records (Assessor's Map 8.5.4BA);
15. Thence along said easterly extension and the south line of said Partition Plat No. 1992-0017, Westerly 607 feet, more or less, to the east line of Parcel 1 of said Partition Plat No. 1992-0017 (Assessor's Map 8.5.4BA);
16. Thence along said east line, Northerly 82 feet, more or less, to the north line of said Parcel 1 (Assessor's Map 8.5.4BA);
17. Thence along said north line, Westerly 252 feet, more or less, to the east right-of-way line of SE Uglow Avenue (Assessor's Map 8.5.4BA);
18. Thence leaving said east right-of-way line, Westerly 36 feet, more or less, to the centerline of SE Uglow Avenue, also being on the City of Dallas city limits line (Assessor's Map 8.5.4BA);
19. Thence along said city limits line, Westerly 3,309 feet, more or less, to the easterly line of Parcel 2 of Partition Plat No. 1992-0036 (Assessor's Map 8.5.5AA);
20. Thence along said easterly line, Northeasterly 816 feet, more or less, to the northerly line of said Parcel 2 (Assessor's Map 7.5.32DD);
21. Thence along said northerly line, Westerly 216 feet, more or less, to the east right-of-way line of SW Hayter Street (Assessor's Map 7.5.32DD);
22. Thence along said east right-of-way line, Northerly 297 feet, more or less, to the south line of Document Number 2016-009487, Polk County Deed Records (Assessor's Map 7.5.32DD);
23. Thence along said south line and the easterly extension thereof, Easterly 475 feet, more or less, to the westerly line of Document Number 2016-002191, Polk County Deed Records (Assessor's Map 7.5.32DD);
24. Thence along said westerly line, Northeasterly 823 feet, more or less, to the south right-of-way line of SW Cherry Street (Assessor's Map 7.5.32DD);
25. Thence along said south right-of-way line, Easterly 138 feet, more or less, to the west right-of-way line of Main Street (Assessor's Map 7.5.32DD);
26. Thence along said west right-of-way line, Northerly 480 feet, more or less, to the north right-of-way line of SW Birch Street (Assessor's Map 7.5.32DA);
27. Thence along said north right-of-way line, Westerly 494 feet, more or less, to the west right-of-way line of SW Church Street (Assessor's Map 7.5.32DA);
28. Thence along said west right-of-way line, Northerly 1,018 feet, more or less, to the south right-of-way line of SW Clay Street (Assessor's Map 7.5.32DA);
29. Thence along said south right-of-way line and the south right-of-way of SE Clay Street, Easterly 1,082 feet, more or less, to the west line of Lot 1, Block 4 of the plat "Gem Addition to Dallas", Volume 1, Page 3, Polk County Plat Records (Assessor's Map 7.5.33CB);

30. Thence along said west line and the southerly extension thereof, Southerly 662 feet, more or less, to the north right-of-way line of SE Maple Street (Assessor's Map 7.5.33CB);
31. Thence along said north right-of-way line, Easterly 1,358 feet, more or less, to the west right-of-way line of SE Uglow Avenue (Assessor's Map 7.5.33CA);
32. Thence along said west right-of-way line, Northerly 512 feet, more or less, to the north line of Lot 10, Block 16 of the plat "Improvement Co. Addition to Dallas Oregon", Volume 19, Page 435, Polk County Plat Records (Assessor's Map 7.5.33CA);
33. Thence along said north line and the westerly extension thereof, Westerly 480 feet, more or less, to the west right-of-way line of SE Lewis Street (Assessor's Map 7.5.33CB);
34. Thence along said west right-of-way line, Northerly 158 feet, more or less, to the south right-of-way line of SE Clay Street (Assessor's Map 7.5.33CB);
35. Thence along said south right-of-way line, Westerly 150 feet, more or less, to the west line of Lot 2, Block 15 of said plat "Improvement Co. Addition to Dallas Oregon" (Assessor's Map 7.5.33CB);
36. Thence leaving said south right-of-way line, Northerly 78 feet, more or less, to west line of Document Number 2017-013058, Polk County Deed Records (Assessor's Map 7.5.33CB);
37. Thence along said west line, Northerly 144 feet, more or less, to the north line of said Deed (Assessor's Map 7.5.33CB);
38. Thence leaving said north line, Northeasterly 16 feet, more or less, to west line of Document Number 2017-014121, Polk County Deed Records (Assessor's Map 7.5.33CB);
39. Thence along said west line and the northerly extension thereof, Northerly 224 feet, more or less, to the north right-of-way line of SE Washington Street (Assessor's Map 7.5.33BC);
40. Thence along said north right-of-way line, Easterly 627 feet, more or less, to the west right-of-way line of SE Uglow Avenue (Assessor's Map 7.5.33BD);
41. Thence along said west right-of-way line, Northerly 324 feet, more or less, to the southerly right-of-way line of SE Mill Street (Assessor's Map 7.5.33BD);
42. Thence along said southerly right-of-way line, Northwesterly 763 feet, more or less, to the southerly extension of the east line of Document Number 2020-019120, Polk County Deed Records (Assessor's Map 7.5.33BC);
43. Thence along said southerly extension and the east line of said Deed, Northerly 219 feet, more or less, to the north line of said Deed (Assessor's Map 7.5.33BC);
44. Thence along said north line, Westerly 75 feet, more or less, feet to westerly line of Document Number 2020-014033, Polk County Deed Records (Assessor's Map 7.5.33BC);
45. Thence along said westerly line, Northerly 40 feet, more or less (Assessor's Map 7.5.33BC);
46. Thence continuing along said westerly line, Westerly 7 feet, more or less, to the southerly extension of the westerly line of Partition Plat No. 2021-0016, Polk County Plat Records (Assessor's Map 7.5.33BC);
47. Thence along said southerly extension and the westerly line of said Partition Plat No. 2021-0016 and the northerly extension thereof, Northerly 468 feet, more or less, to the

- south line of the first described parcel in Document Number 2009-000886, Polk County Deed Records (Assessor's Map 7.5.33BC);
48. Thence along said south line, Easterly 70 feet, more or less, to the westerly line of said Partition Plat No. 2021-0016 (Assessor's Map 7.5.33BC);
 49. Thence along said westerly line, Northerly 125 feet, more or less, to the easterly right-of-way line of SE Academy Street (Assessor's Map 7.5.33BC);
 50. Thence along said easterly right-of-way line, Northerly 73 feet, more or less, to the north right-of-way line of SE Academy Street (Assessor's Map 7.5.33BC);
 51. Thence along said north right-of-way line, Westerly 76 feet, more or less, to the westerly line of said Partition Plat 2021-0016 (Assessor's Map 7.5.33BC);
 52. Thence along said westerly line, Northerly 81 feet, more or less, to the northerly line of said Partition Plat No. 2021-0016 (Assessor's Map 7.5.33BC);
 53. Thence along said northerly line, Southeasterly 822 feet, more or less, to the most easterly line of said Partition Plat No. 2021-0016 (Assessor's Map 7.5.33BC);
 54. Thence along said easterly line and the southwesterly extension thereof, Southwesterly 492 feet, more or less, to the northerly line of Document Number 2001-004720 (Assessor's Map 7.5.33BD);
 55. Thence along said northerly line, Southeasterly 287 feet, more or less, to the northerly right-of-way line of SE Mill Street (Assessor's Map 7.5.33BD);
 56. Thence along said northerly right-of-way line, Southeasterly 283 feet, more or less, to the westerly line of Document Number 2012-013276, Polk County Deed Records (Assessor's Map 7.5.33BD);
 57. Thence along said westerly line, Northerly 492 feet, more or less, to the northerly line of said Deed (Assessor's Map 7.5.33BD);
 58. Thence along said northerly line, Southeasterly 1,028 feet, more or less, to the northerly line of Lot "F" of the plat "Alderbrook – Phase I", Volume 10, Page 36, Polk County Plat Records (Assessor's Map 7.5.33AC);
 59. Thence along the northerly line of said plat and the northerly line of Partition Plat No. 98-0005, Polk County Plat Records, Westerly 619 feet, more or less, to the west line of Parcel 1 of said Partition Plat No. 98-0005 (Assessor's Map 7.5.33BD);
 60. Thence along said west line and the southerly extension thereof, Southerly 197 feet, more or less, to the south right-of-way line of SE Azalea Avenue (Assessor's Map 7.5.33BD);
 61. Thence along said south right-of-way line, Easterly 153 feet, more or less, to the west line of Lot 18 of said plat "Alderbrook – Phase I" (Assessor's Map 7.5.33CA);
 62. Thence along said west line and the southerly extension thereof, Southerly 315 feet, more or less, to the northerly line of Document Number 2021-003757, Polk County Deed Records (Assessor's Map 7.5.33CA);
 63. Thence along said northerly line, Westerly 43 feet, more or less, to the west line of said Deed (Assessor's Map 7.5.33CA);
 64. Thence along said west line, Southerly 150 feet, more or less, to the northerly right-of-way line of SE Miller Avenue (Assessor's Map 7.5.33CA);
 65. Thence leaving said northerly right-of-way line, Southerly 61 feet, more or less, to the intersection of the southerly right-of-way of SE Miller Avenue and the northerly extension of the east line of Document Number 2021-017475, Polk County Deed Records (Assessor's Map 7.5.33CA);

66. Thence along said northerly extension and the east line of said Deed, Southerly 256 feet, more or less, to the south line of Parcel II said Deed (Assessor's Map 7.5.33CA);
67. Thence along said south line and the westerly extension thereof, Westerly 281 feet, more or less, to the east right-of-way line of SE Uglow Avenue (Assessor's Map 7.5.33CA);
68. Thence along said east right-of-way line, Southerly 516 feet, more or less, to the north line of Document Number 2013-009007, Polk County Deed Records (Assessor's Map 7.5.33CA);
69. Thence along said north line, Easterly 450 feet, more or less, to the east line of said Deed (Assessor's Map 7.5.33CA);
70. Thence along said east line, Southerly 366 feet, more or less, to the north right-of-way line of SE Birch Street (Assessor's Map 7.5.33CA);
71. Thence along said north right-of-way line and the north right-of-way line of Southern Pacific Railroad, Easterly 3,199 feet, more or less, to the west right-of-way line of SE Godsey Road (Assessor's Map 7.5.34CB);
72. Thence along said west right-of-way line, Northerly 177 feet, more or less, to the westerly extension of the north line of Parcel 3 of Partition Plat No. 1995-0034, Polk County Plat Records (Assessor's Map 7.5.34CB);
73. Thence along said westerly extension and the north line of said Parcel 3, Easterly 905 feet, more or less, to the westerly right-of-way line of SE Jonathan Avenue (Assessor's Map 7.5.34CB);
74. Thence along said westerly right-of-way line, Southerly 66 feet, more or less, to the south right-of-way line of SE Jonathan Avenue (Assessor's Map 7.5.34CB);
75. Thence along said south right-of-way line, Easterly 68 feet, more or less, to the east line of said Parcel 3 (Assessor's Map 7.5.34CB);
76. Thence along said east line, Southerly 120 feet, more or less, to the north right-of-way line of Southern Pacific Railroad (Assessor's Map 7.5.34CA);
77. Thence along said north right-of-way line, Easterly 1,173 feet, more or less, to the east line of Partition Plat No. 2010-0006, Polk County Plat Records (Assessor's Map 7.5.34CA);
78. Thence along the southerly extension of said east line, Southerly 20 feet, more or less, to the centerline of Southern Pacific Railroad (Assessor's Map 7.5.34CA);
79. Thence along said centerline, Easterly 501 feet, more or less, to the City of Dallas city limits line (Assessor's Map 7.5.34C);
80. Thence along said city limits line, Southerly 21 feet, more or less, to the intersection of the south right-of-way line of Southern Pacific Railroad and the east line of the David Grant Donation Land Claim No. 65 (Assessor's Map 7.5.34C);
81. Thence along said east line, Southerly 1,071 feet, more or less, to the southeast corner of the north one-half of the David Grant Donation Land Claim (D.L.C.) No. 65 (Assessor's Map 7.5.34C);
82. Thence along the south line of the north one-half of D.L.C. No. 65, Westerly 1,574 feet, more or less, to the east line of Document Number 2002-003573, Polk County Deed Records (Assessor's Map 7.5.34CC);
83. Thence along said east line, Southerly 212 feet, more or less, to the Point of Beginning (Assessor's Map 8.5.3BB).

Excepting therefrom;

Beginning at the northeast corner of Lot 2, Block 1 of the plat "Brookside Subdivision", Volume 8, Page 41, Polk County Plat Records (Assessor's Map 7.5.34CC);

84. Thence along the east line of said plat, Southerly 381 feet, more or less, to the south line of said plat (Assessor's Map 7.5.34CC);
85. Thence along said south line, Westerly 170 feet, more or less, to the east right-of-way line of SE Godsey Road (Assessor's Map 7.5.34CC);
86. Thence along said east right-of-way line, Northerly 381 feet, more or less, to the westerly extension of the north line of said plat (Assessor's Map 7.5.34CC);
87. Thence along said westerly extension and the north line of said plat, Easterly 170 feet, more or less, to the Point of Beginning (Assessor's Map 7.5.34CC).

Also Excepting therefrom;

Beginning at the northwest corner Lot 1, Block 3 of the plat "Godsey Subdivision", Volume 5, Page 43, Polk County Plat Records (Assessor's Map 7.5.34CC);

88. Thence along the north line of said plat, Easterly 325 feet, more or less, to the east line of said plat (Assessor's Map 7.5.34CC);
89. Thence along said east line, Southerly 10 feet, more or less, to the north line of Book 313, Page 1700, Polk County Book of Records (Assessor's Map 7.5.34CC);
90. Thence along said north line, Easterly 120 feet, more or less, to the west right-of-way line of SE Godsey Road (Assessor's Map 7.5.34CC);
91. Thence along said west right-of-way line, Southerly 625 feet, more or less, to the south line of Document Number 2006-005592, Polk County Deed Records (Assessor's Map 7.5.34CC);
92. Thence along said south line and the south line of Document Number 2020-011088, Polk County Deed Records, Westerly 482 feet, more or less, to the west line of said Deed (Assessor's Map 7.5.34CC);
93. Thence along said west line, Northerly 85 feet, more or less, to the north line of said Deed (Assessor's Map 7.5.34CC);
94. Thence along said north line, Easterly 62 feet, more or less, to the west line of said plat (Assessor's Map 7.5.34CC);
95. Thence along said west line, Northerly 575 feet, more or less, to the Point of Beginning (Assessor's Map 7.5.34CC).

The above described tract of land contains 423 acres, more or less.

6/23/2022



Michael S. Kalina

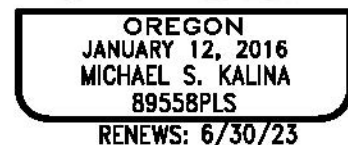

SEE SHEET 4



SEE SHEET 3

SEE SHEET 2

AKS DRAWING FILE: 9497_URB_MAP.DWG LAYOUT: 1

DESIGNED BY:
 DRAWN BY: WCB
 MANAGED BY: MSK
 CHECKED BY: MSK
 DATE: 6/23/2022

REGISTERED
 PROFESSIONAL
 LAND SURVEYOR

OREGON
 JANUARY 12, 2016
 MICHAEL S. KALINA
 89558PLS
 RENEWS: 6/30/23

REVISIONS

JOB NUMBER
 9497

SHEET
 1

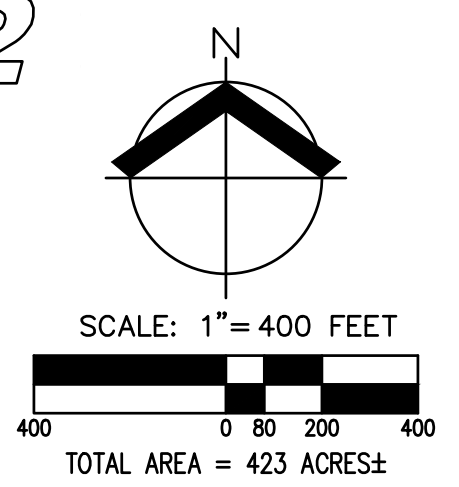

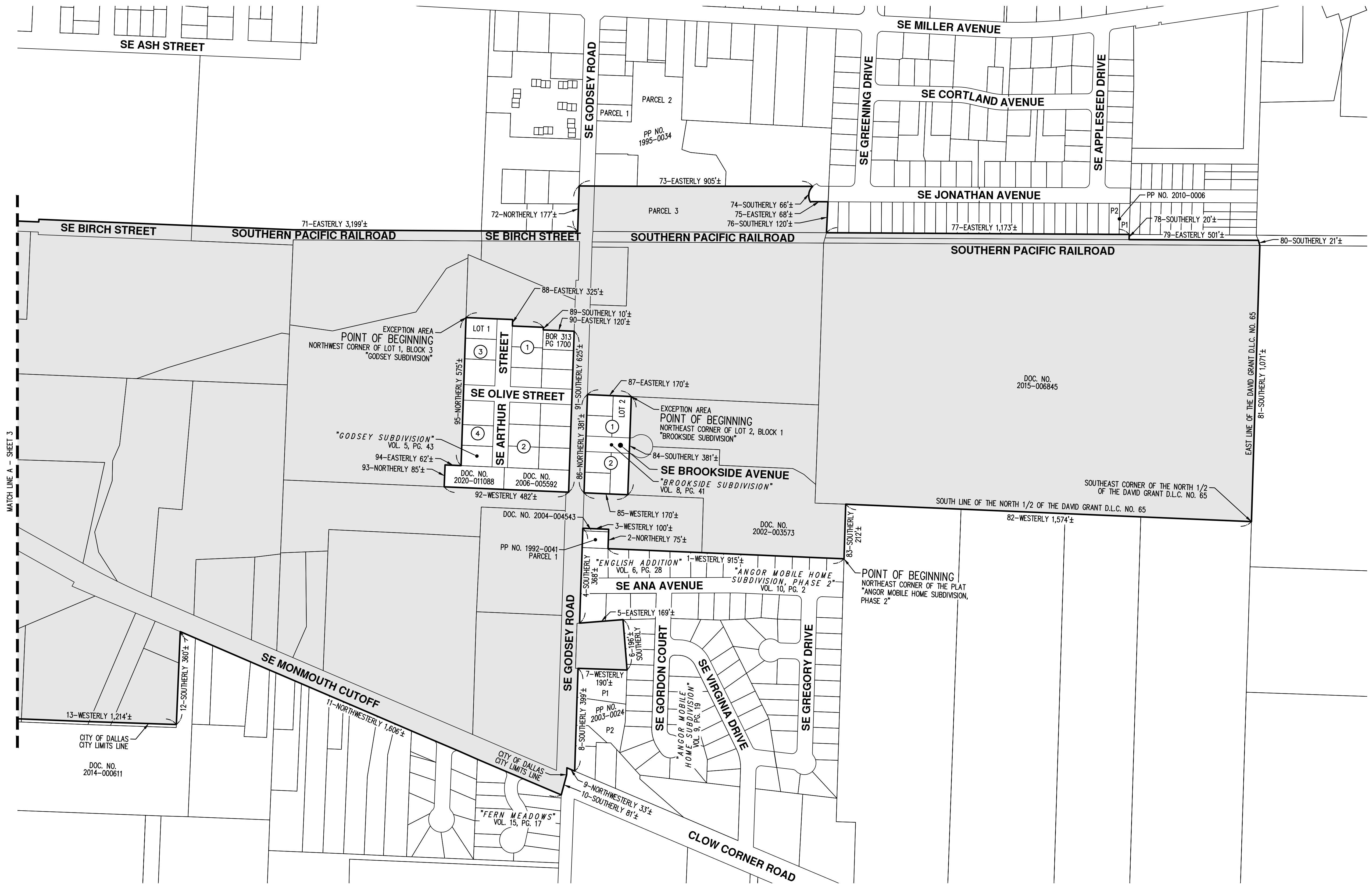

MATCH LINE A - SHEET 3

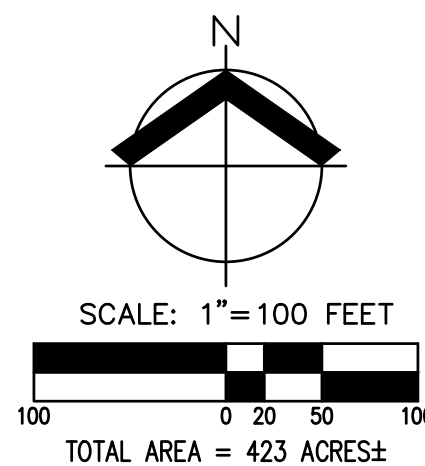

DESIGNED BY:	
DRAWN BY:	WCB
MANAGED BY:	MSK
CHECKED BY:	MSK
DATE:	6/23/2022
REGISTERED PROFESSIONAL LAND SURVEYOR	
<i>Michael S. Kalina</i>	
OREGON	
JANUARY 12, 2016	
MICHAEL S. KALINA	
89558PLS	
RENEWS: 6/30/23	
REVISIONS	
JOB NUMBER	9497
SHEET	2

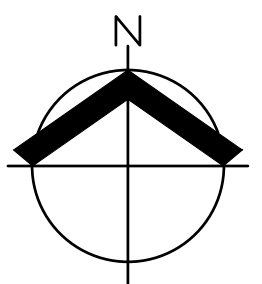
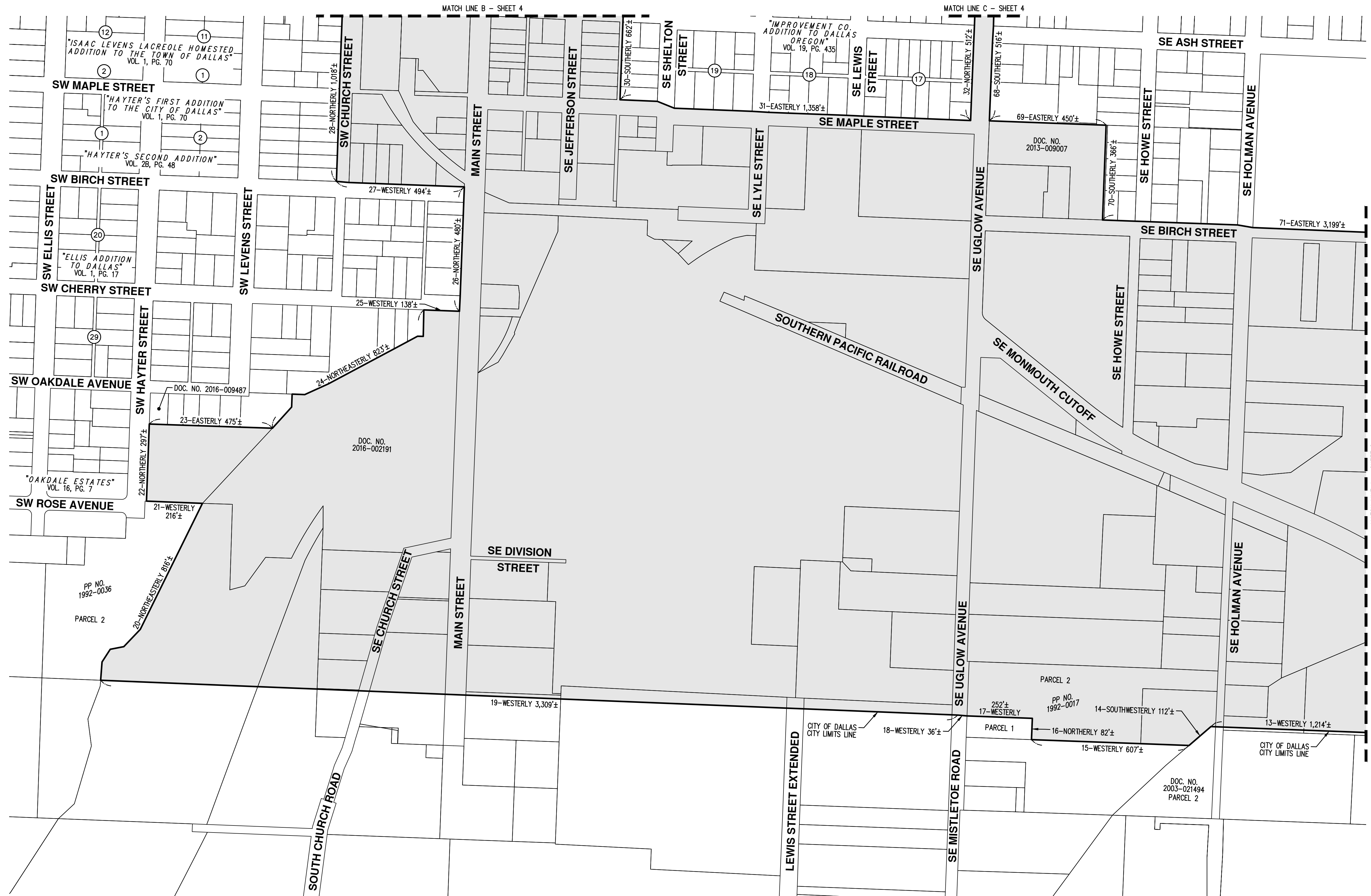

SCALE: 1" = 100 FEET
 0 20 50 100
 TOTAL AREA = 423 ACRES±

CITY OF DALLAS
URBAN RENEWAL AREA
DALLAS
 POLK COUNTY
OREGON

MAP OF URBAN RENEWAL AREA

DESIGNED BY:
 DRAWN BY: WCB
 MANAGED BY: MSK
 CHECKED BY: MSK
 DATE: 6/23/2022
 REGISTERED PROFESSIONAL LAND SURVEYOR

Michael S. Kalina
 OREGON
 JANUARY 12, 2016
 MICHAEL S. KALINA
 89558PLS
 RENEWS: 6/30/23

REVISIONS

JOB NUMBER
9497
 SHEET
3

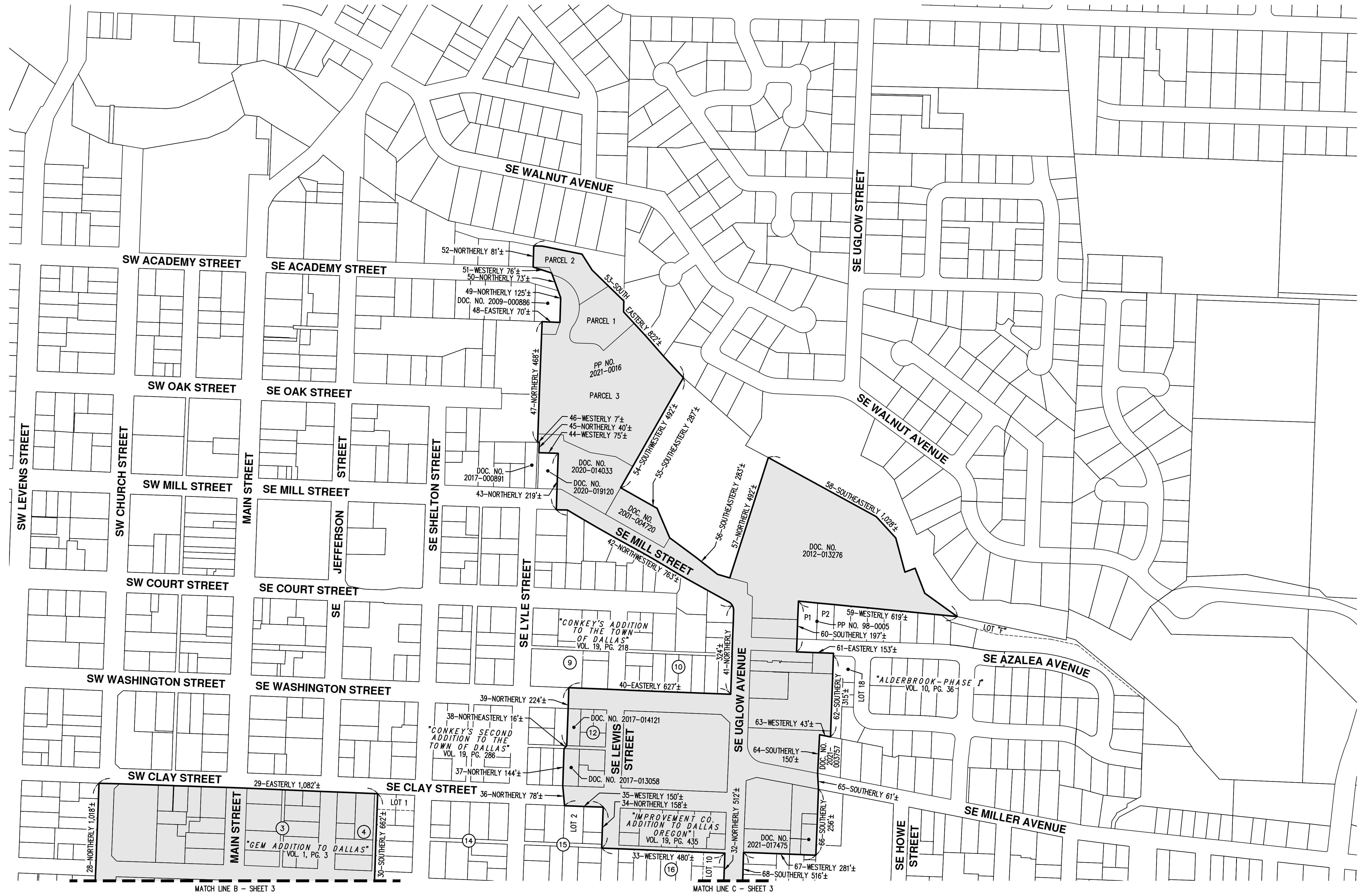

MATCH LINE B - SHEET 3

MATCH LINE C - SHEET 3

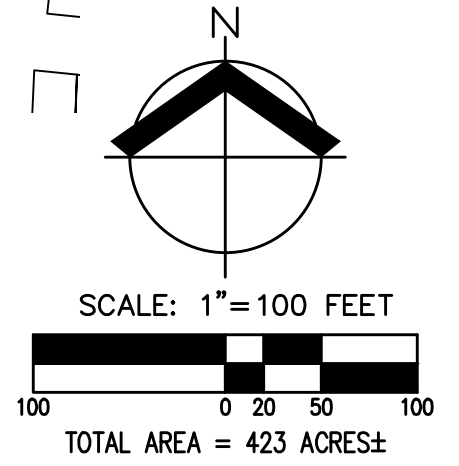

DESIGNED BY:
 DRAWN BY: WCB
 MANAGED BY: MSK
 CHECKED BY: MSK
 DATE: 6/23/2022
 REGISTERED PROFESSIONAL LAND SURVEYOR
 OREGON
 JANUARY 12, 2016
 MICHAEL S. KALINA
 89558PLS
 RENEWS: 6/30/23



JOB NUMBER
 9497
 SHEET
 4

REVISIONS

TOTAL AREA = 423 ACRES±

City of Dallas South Dallas Urban Renewal District

June 2022
Acres: 423.3

-  Urban Renewal Dist. Boundary
-  Urban Renewal Dist. Parcels

500 0 500 1000 ft

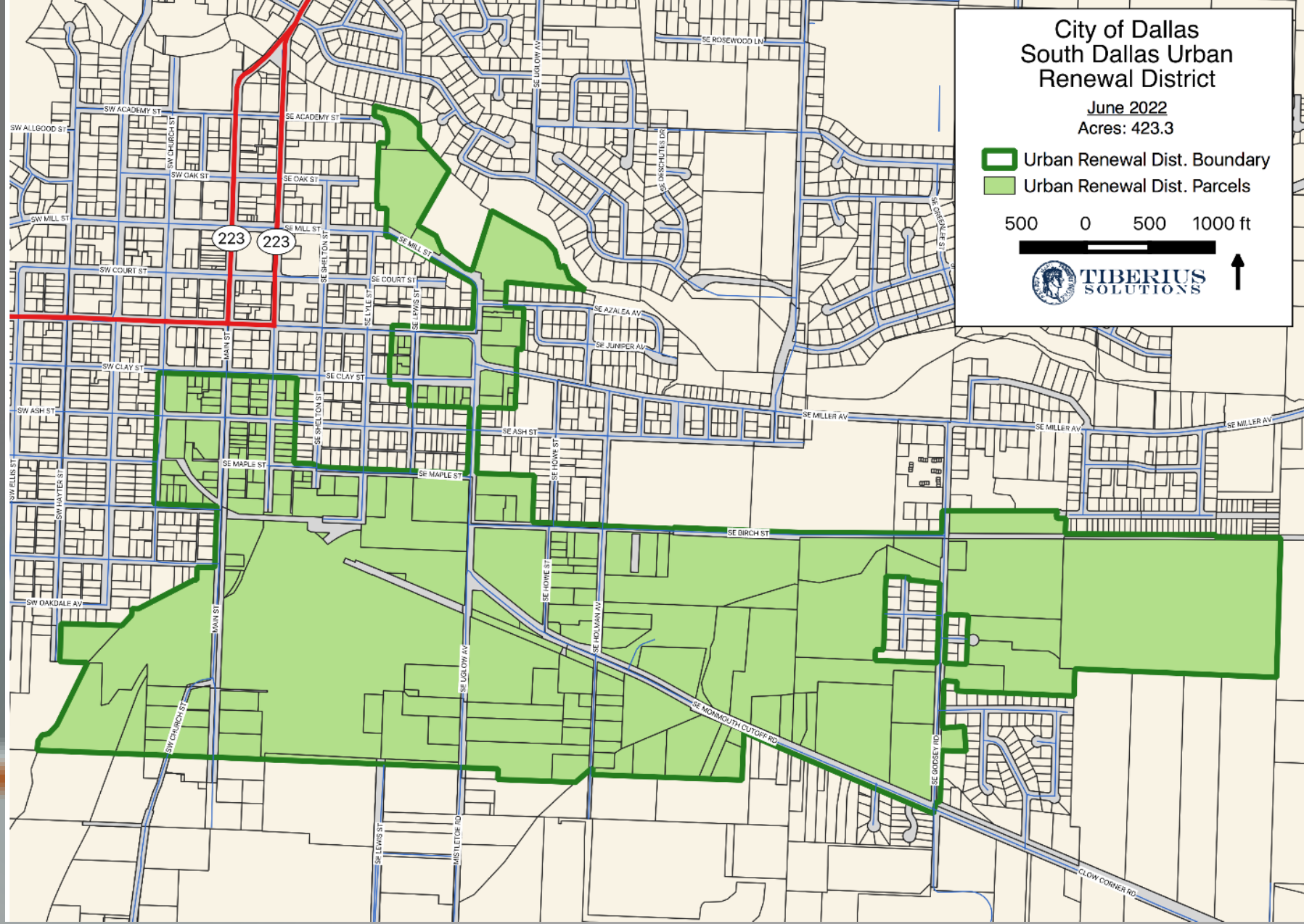

What is the S. Dallas URD?

- 423 acres, mostly industrial
- Public & private investment & projects
- 15 identified project areas in two broad categories

Project	Constant \$2022	Year of expenditure \$
Public Infrastructure, Facilities & Planning	(\$10,750,000)	(19,366,425)
Private Sector/ Economic Development	(\$11,500,000)	(20,717,571)
Admin & Staffing including finance fees	(\$858,498)	(1,501,885)
TOTAL:	(\$23,108,498)	(\$41,585,881)

PROJECTS

PUBLIC INFRASTRUCTURE, FACILITIES & PLANNING

1. Floodway study (Mill Site/ N. Fork Ash Creek)
2. Monmouth Cutoff Road, Uglow Street improvements (from eastern City limits to intersection; may include new intersection; build to City urban design standards)
3. Mill Site transportation improvements (new east-west transportation corridors through the current Mill Site)
4. Jefferson Street/Main Street couplet improvements to the south to connect into current Mill Site area
5. Ash Creek improvements (a portion of the creek lies underneath the Mill Site)

PROJECTS (continued)

PUBLIC INFRASTRUCTURE, FACILITIES & PLANNING

6. Other area roadway, pedestrian, bicycle & rail improvements throughout Area
 7. Area water service extensions where needed
 8. Area sanitary sewer service upgrades & extensions where needed
 9. Purple pipe development (recycled wastewater for industrial uses)
 10. Trails systems improvements & extensions, potentially along Ash Creek and at the south end of the current Mill Site
-

PROJECTS (continued)

PRIVATE SECTOR/ ECONOMIC DEVELOPMENT

1. Site certification assistance (State of Oregon industrial site certification program)
2. New & existing business assistance programs
3. City fee & Systems Development Charges (SDC) waiver assistance for targeted businesses
4. Targeted commercial marketing
5. Targeted Mill Site improvements

ADMINISTRATION & STAFFING

Authorizes expenditures for the administrative costs associated with managing the Area including budgeting and annual reporting, planning and the implementation of projects in the Area.

QUESTIONS?



South Dallas

URBAN RENEWAL
DISTRICT

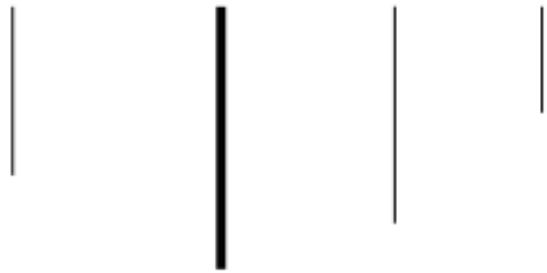

**CITY OF DALLAS
SOUTH DALLAS URBAN RENEWAL DISTRICT
ADVISORY COMMITTEE
STAFF REPORT**

DATE: March 28, 2024
AGENDA ITEM NO.
TOPIC: Property Owner Initial Outreach
PREPARED BY: Tyler Ferrari
APPROVED BY:
ATTACHMENTS: A. Letter
B. Map of Properties
C. List of Properties

RECOMMENDED ACTION:

N/A – for information only

BACKGROUND:

Staff is making an effort to proactively reach out to property owners of targeted properties in the Urban Renewal District. This letter is part of this outreach that will go out to the targeted owners on this list. These parcels were selected with the following criteria

- Acreage
- Improved Value

Properties are on the cusp of one or both of these categories were also included.

SUMMARY TIMELINE:

N/A

FISCAL IMPACT:

N/A

SUGGESTED MOTION:

N/A

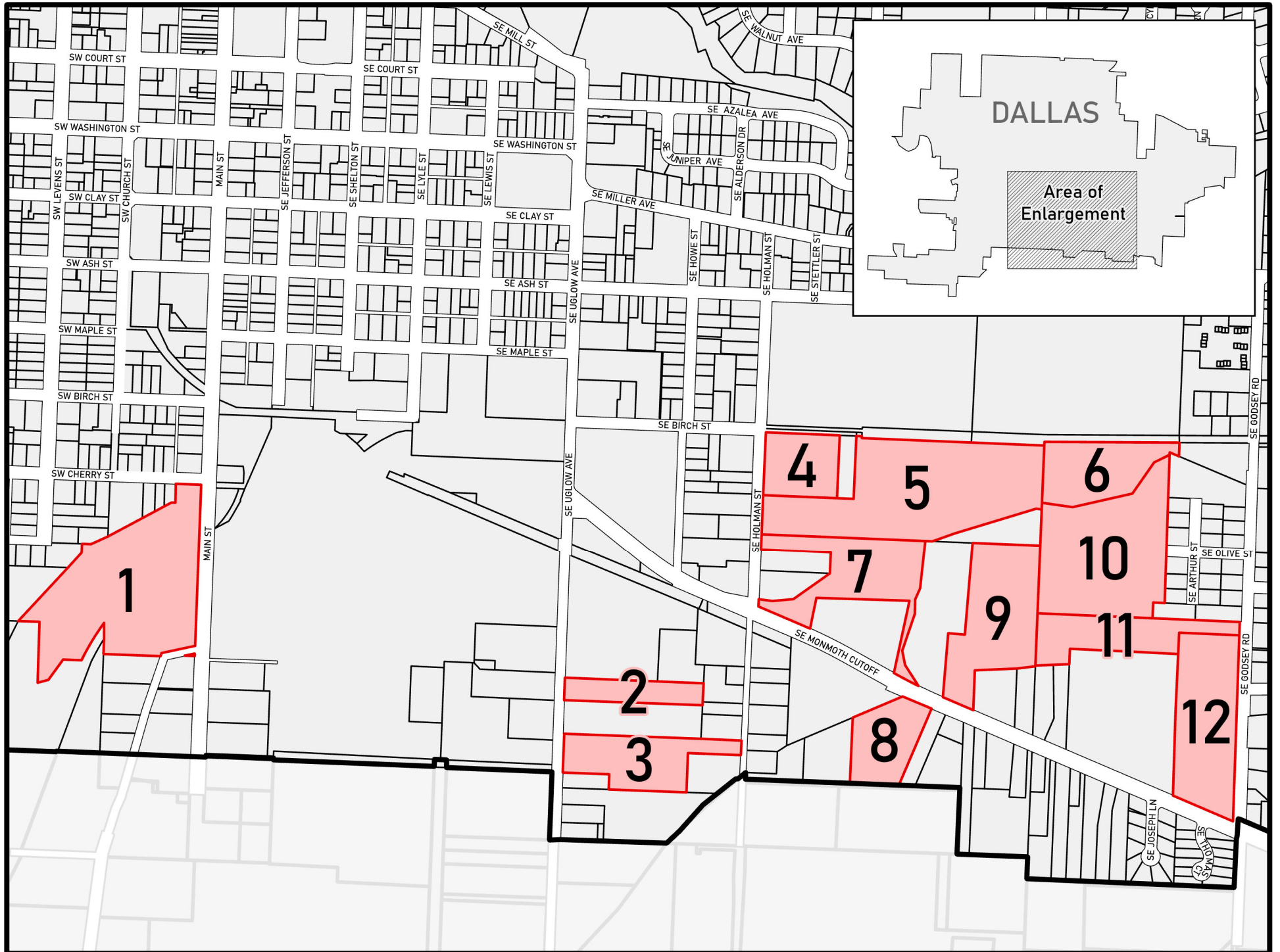

Owner Name	Site Address	Mailing Address	Acreage	Improved Value	Sold After 2010?
850 SE MONMOUTH CUT OFF ROAD LLC	850 SE Monmouth Cutoff Road	PO BOX 1089 DALLAS OR 97338	5.88	\$ 113,400.00	Yes
Kam Properties LLC	1010 SE Monmouth Cutoff Road	1674 SW CLAY ST DALLAS OR 97338	7.04	\$ -	Yes
WILL GREG A & WILL RODNEY L	1820 SE UGLOW AVE	PO BOX 370 DALLAS OR 97338	3	\$ -	Yes
LARA SONYA	1918 Uglow Ave SE	1940 UGLOW AVE SE DALLAS OR 97338	4.55	\$ -	No
WHITE WILLIAM L & CARISSA J	965/973 SE Monmouth Cutoff Road	16252 SHADY LN MONMOUTH OR 97361	3.56	\$ 75,120.00	Yes
HARRISON KEN & HERB BRETT	1775 SE Godsey	10355 LIBERTY RD S SALEM OR 97306	7.14	\$ -	Yes
BERGMAN OLE VICTOR ETAL, RVC LVG TRUST	Taxlot: 1121 and Taxlot: 1305	541 HOPKINS ST FALLS CITY OR 97344	14.6	\$ -	Yes
GLORIETTA BAY LLC	1500 SE Holman Ave	100 NW FERRY ST ALBANY OR 97321	4.32	\$ -	Yes
FRED TEBB & SONS OREGON LLC	1415 SE HOLMAN AVE DALLAS OR 97338	1415 SE HOLMAN AVE DALLAS OR 97338	<1	\$ -	Yes
FRED TEBB & SONS OREGON LLC	1415 SE HOLMAN AVE DALLAS OR 97338	1415 SE HOLMAN AVE DALLAS OR 97338	<1	\$ 1,277,810.00	Yes
FERRUM PROPERTIES LLC	1501 Main	PO BOX 5191 SALEM OR 97304-0191	6.88	\$ -	Yes
			56.97	\$ 1,466,330.00	Totals